



OUTDOOR LIGHTING CONFORMANCE CERTIFICATION

(This form covers all outdoor lighting excluding street lights and parking lot lights)

Town of Fairview Lighting Regulations

- Article 3.14 of the Town of Fairview Code of Ordinances
- Article 5 of the Commercial Plan Development District (CPDD) Standards and Guidelines (Adopted by Ordinance 2014-9-11B, as amended)

Please check if residential or commercial:

Residential Commercial

Fairview Address:

Please check the correct lighting district (Map located on page 3):

District 1 District 2

If in District 1, Article 3.14 of the Town of Fairview Code of Ordinances and Article 5 of the CPDD Standards and Guidelines requires the following (check the following if compliant):

- All exterior lighting fixture details have been submitted to the Town of Fairview for review and have been approved Article
- Lighting glare from any lighting source will not be directly visible from public view or from a residential unit and a maximum average of 1-foot candle at residential property lines has not been exceeded
- All fixtures are full cutoff. Any proposed fixtures not meeting the full cutoff requirement must be approved by minor warrant. All outdoor lighting fixtures approved by minor warrant shall not exceed 20,000 lumens per developed acre
- Lighting levels conform with standards established in Article 3.14 of the Town of Fairview Code of Ordinances and Article 5 of the CPDD Standards and Guidelines
- Lighting elements do not include flood, cobra head (unless LED), HID – mercury vapor and sodium vapor, high pressure sodium and fluorescent lights (except fluorescent bulbs that screw into standard socket fixtures)
- All other applicable provisions of Article 3.14 of the Town of Fairview Code of Ordinances and Article 5 of the CPDD Standards and Guidelines have been met on this site

If in District 2, Article 3.14 of the Town of Fairview Code of Ordinances requires the following (check the following if compliant):

- All exterior lighting fixture details have been submitted to the Town of Fairview for review and have been approved
- All outdoor lighting fixtures have been designed, located, installed, aimed downward or towards structures, retro fitted if necessary, and maintained in order to prevent glare, light trespass, and light pollution
- Light trespass at property lines does not exceed the maximum of 0.20-foot candles
- Light fixtures conform with shielding requirements applicable to fully shielded, partially shielded, and unshielded
- Lighting levels conform with standards established in Article 3.14 of the Town of Fairview Code of Ordinances
- All lamp types for new security lights are LED, metal halide, high-pressure sodium or low-pressure sodium. Security lights intended to illuminate a perimeter (such as a fence line) shall include motion sensors and be designed to be off unless triggered by an intruder located within five feet of the perimeter. The zone of activation sensors must be within the property boundaries of the property wishing to be illuminated.
- A maximum limit of 50,000 lumens per developed acre for all lighting irrespective of shielding conditions has not been exceeded. Unshielded and partially shielded lighting are limited to a maximum of 10,000 lumens per developed acre
- All floodlighting, that is not motion activated, is full cutoff or permanently directed downward
- Upward lighting is used in the form of one narrow cone spotlight for flags, statues, public art or other objects of interest that cannot be illuminated with down-lighting
- All other applicable provisions of Article 3.14 of the Town of Fairview Code of Ordinances have been met on this site

I, _____, do hereby certify that the exterior lighting
 printed name

meets or exceeds the outdoor lighting standards of the Fairview Code of Ordinances.

Signature: _____ Date: _____

STATE OF TEXAS §

COUNTY OF _____ §

This instrument was acknowledged before me on the _____ day of _____,

20_____, by _____

 Notary Public State of Texas



Town of Fairview Lighting Districts

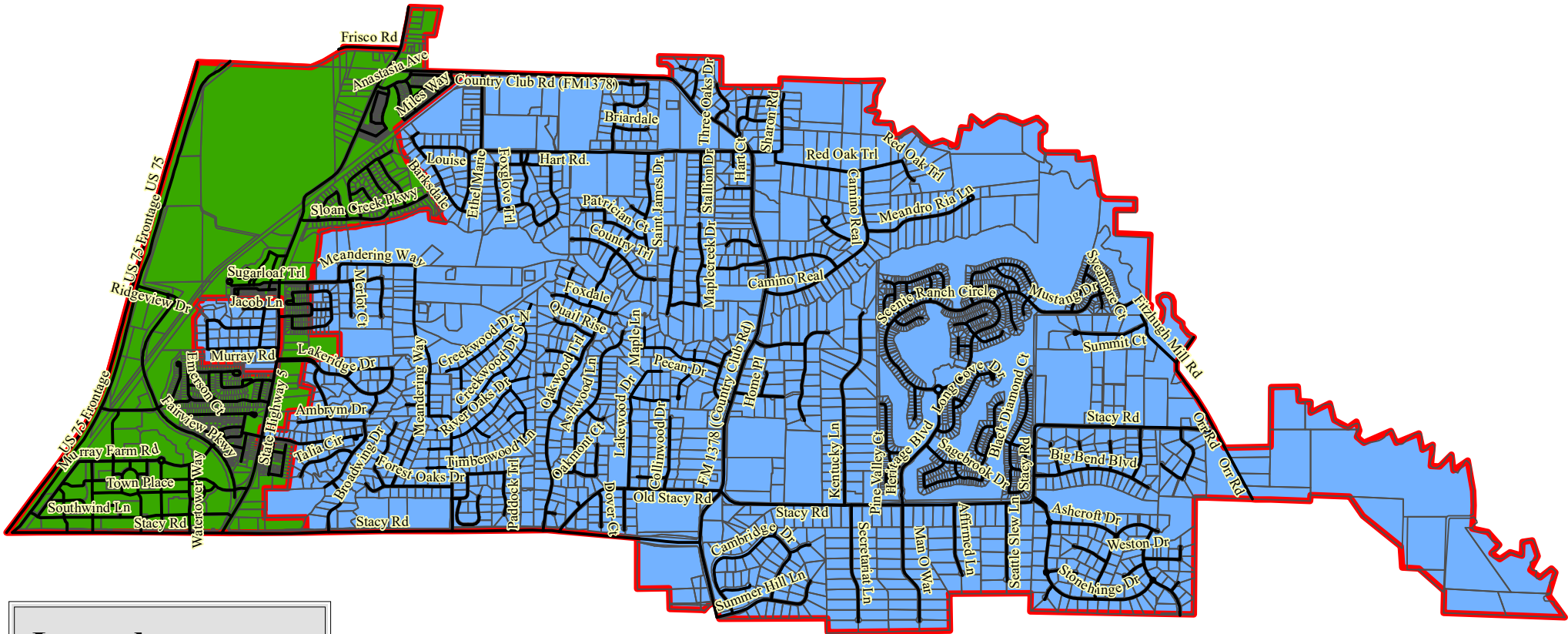

Legend

- Streets
- Fairview Parcels
- District 1
- District 2



Examples of Acceptable / Unacceptable Lighting Fixtures

Unacceptable / Discouraged

Fixtures that produce glare and light trespass

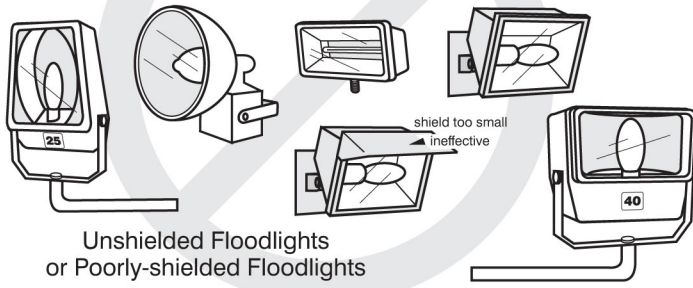

Unshielded Floodlights or Poorly-shielded Floodlights

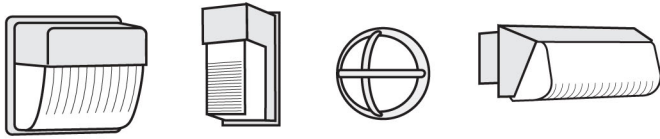

Unshielded Wallpacks & Unshielded or Poorly-shielded Wall Mount Fixtures

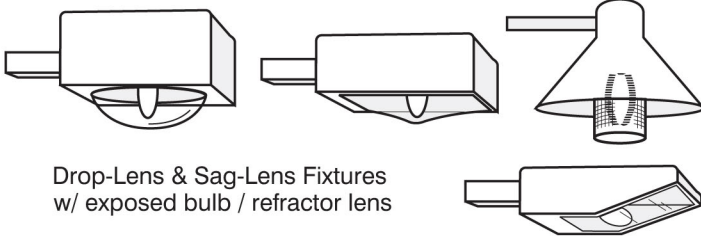
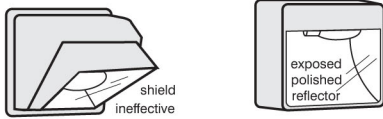

Drop-Lens & Sag-Lens Fixtures w/ exposed bulb / refractor lens

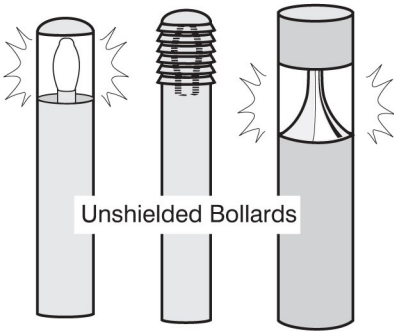

Unshielded Bollards

Unshielded Streetlight

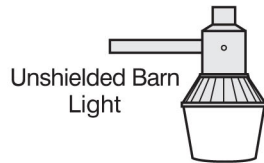

Unshielded Barn Light

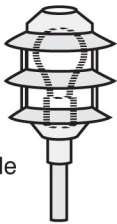

Louvered 'Marine' style Fixtures

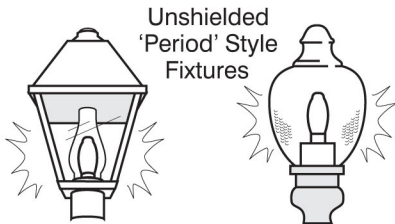

Unshielded 'Period' Style Fixtures



Unshielded PAR Floodlights

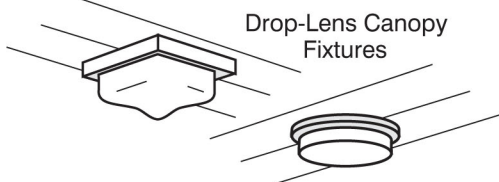

Drop-Lens Canopy Fixtures

Acceptable

Fixtures that shield the light source to minimize glare and light trespass and to facilitate better vision at night

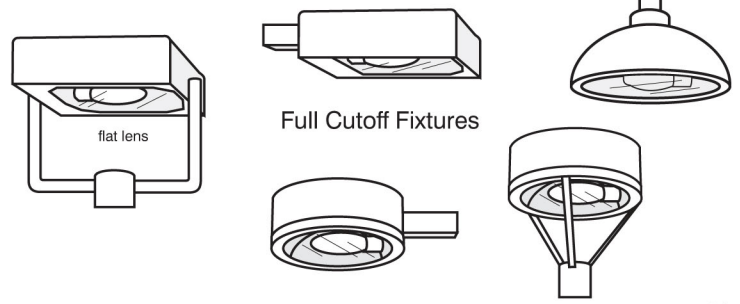

Full Cutoff Fixtures

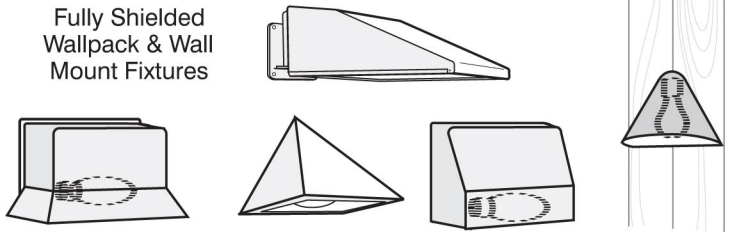

Fully Shielded Wallpack & Wall Mount Fixtures

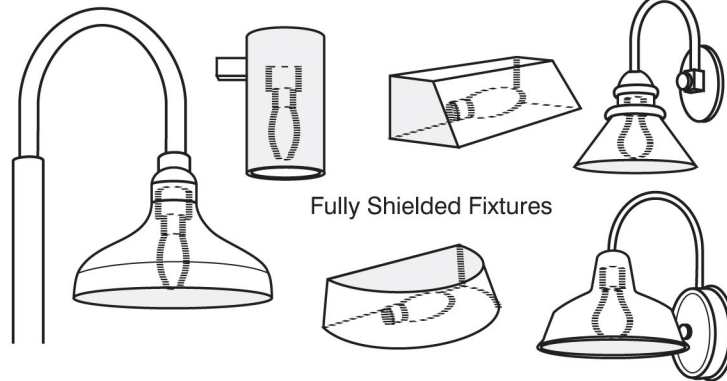

Fully Shielded Fixtures



Full Cutoff Streetlight

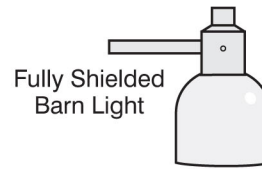

Fully Shielded Barn Light

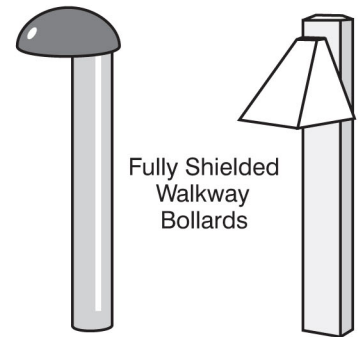

Fully Shielded Walkway Bollards



Fully Shielded Decorative Fixtures

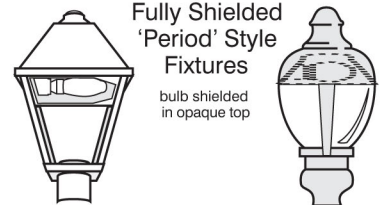

Fully Shielded 'Period' Style Fixtures

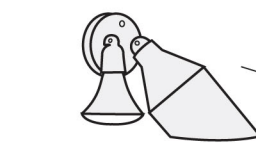

Shielded / Properly-aimed PAR Floodlights

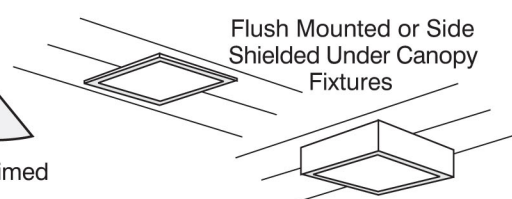

Flush Mounted or Side Shielded Under Canopy Fixtures