



RESIDENTIAL ADDITIONS AND REMODEL PACKET

Town of Fairview

372 Town Place

Fairview Texas 75069

Phone: 972.886.4209

Fax: 972.548.0268

Inspection Line: 972.886.4250

inspections@fairviewtexas.org

permits@fairviewtexas.org



MEMORANDUM

DATE: SEPTEMBER 9, 2025
TO: CONTRACTORS, BUILDERS, SUBCONTRACTORS
FROM: BUILDING INSPECTION DEPARTMENT,
SUBJECT: WATER METER PROTECTIVE BARRICADE POLICY

Beginning September 9, 2025, this Policy will be in effect.

All water meters must be protected from damage on all construction sites. No construction materials shall be placed upon the meter/meter can, no traffic shall drive over the meter/meter can, there shall be no dirt/trash in the meter can, and the following requirements shall be met.

- The protective barricade shall be a three-foot square, with a minimum height of twenty-four inches.
- The protective barricade must be constructed of two by four lumber, at a minimum, and be anchored to the ground, forming a three-foot-by-three-foot area of protection for the water meter.
- The protective barricade shall allow access for the meter to be read.
- The protective barricade must be installed within twenty-four hours of the meter installation.
- The protective barricade shall remain in place for the duration of construction on the site.
- Nothing shall be set upon or obstruct the water meter from being accessible for reading at any time during the duration of construction.

Please observe this policy as there will be no warnings for violations. Any violation will result in a citation being issued to the individual responsible for the construction site.

The consequences of violations will be as follows:

Construction inspection: \$200.00.

Repair of any damage to water line (Town of Fairview side of meter) including material and labor

Cost of replacement / reset meter labor if required

Cost of Meter Box /reset box labor if required



Asbestos Removal

Survey Requirements for Commercial & Public Buildings

If an owner of a public or commercial building or more than four units for residential will be disturbing any building materials during his or her renovation or demolition, the owner is required to have the materials surveyed for asbestos by a licensed asbestos professional. A survey is required regardless of the age of the building.

One exception to that rule can be found in the Texas Asbestos Health Protection Rules in section 295.34. It states that if a licensed asbestos inspector, a Texas-registered architect, or a Texas licensed professional engineer reviews all the building's material safety data sheets and, subsequently, provides a written certification that no materials contain asbestos, then a building owner can use that certification in lieu of an asbestos survey.

All municipalities must ensure that building owners have an asbestos survey or written certification as described above prior to issuing any building permits for renovations or demolition. Cities do not have the authority to enforce the state and federal asbestos regulations; however, they do have the authority to withhold their own city permits if the asbestos requirements haven't been met (this law went into effect in 2002).

Building owners are held responsible for complying with these asbestos regulations. In many cases, owners may have their contracted asbestos professionals ensure that the requirements are met; however, the responsibility lies solely with the building owner.



TOWN OF FAIRVIEW
RESIDENTIAL ADDITION/REMODEL/ACCESSORY
STRUCTURE PERMIT APPLICATION

Project Address _____ Subdivision/Lot/Block _____

Property Owner (Name, Address, Phone, & Email) _____

General Contractor: _____ Phone: _____ Email _____

General Contractor Address: _____

Trash Hauler Contractor: Republic Services is the required trash hauler. If you have questions, please contact them at 972.422.2341

RESIDENTIAL WORK BEING DONE:

- Addition Pergola Remodel Outdoor Kitchen
Detached Accessory Structure Residential Demo

Scope of Work: _____

Valuation of work \$: _____ Square Footage _____ in/ft (Total under roof)

Subject property is ___ or is not ___ within the flood hazard area. Required lowest floor elevation is _____.

NOTE: There may be required forms and information sheets for the specific type of work being done.. Please contact the permits department for required submittal.

Remote Virtual Inspections RVI Instructions:

- All remote inspections should be scheduled a minimum of one business day prior to the requested date.
Schedule inspection either on-line or by telephone. inspections@fairviewtexas.org / 972-886-4250
Schedule after-hours or emergency inspections on a case-by-case basis. Additional fees apply.
Video telephony platform: Face-time (Note: Please leave a call back number for the inspector if you are requesting face time.)
When scheduling the inspection, provide the address, permit number, and type.
Remote virtual inspection (RVI) may be done via live stream, pictures, video or any combination.

Electric Distributor: ___ ONCOR ___ GCEC Gas Provider: ___ ATMOS ___ COSERV Note: Please allow 7-10 business days for processing

NOTICE TO APPLICANT: This permit is issued based on information furnished in this application and on any submitted plans and is subject to the provisions and requirements of the Town of Fairview Code of Ordinances and any other applicable ordinance. This permit is used only for the purpose of allowing construction of a building or structure conforming to the codes and ordinances of the Town, regardless of information and/or plans submitted. Separate subcontractor permits are required. The permit holder is required to use only subcontractors registered with the Town of Fairview, where such a requirement is applicable.

APPLICANT SIGNATURE _____ DATE _____

TOWN OF FAIRVIEW, 372 TOWN PLACE, FAIRVIEW, TEXAS 75069, 972-562-0522

ALL PERMITS MUST BE SUBMITTED TO: permits@fairviewtexas.org



GENERAL CONTRACTOR REGISTRATION APPLICATION

FEE: \$50.00

The general contractor registration is valid for one year and is renewed annually on the application date.

The annual fee is \$ 50.00

A copy of your driver's license and certificate of insurance is required.

NAME OF COMPANY: _____
NAME OF CONTACT: _____
ADDRESS OF COMPANY: _____
CITY: _____ STATE: _____ ZIP: _____
MAIN PHONE NUMBER: _____
CONTACT PHONE NUMBER: _____
EMAIL: _____
DRIVERS LICENSE NUMBER: _____ STATE: _____

I understand and agree that the above-mentioned shall be responsible for continuous supervision of all installations and repairs performed in the Town of Fairview under the above-named contractor. I will request all necessary inspections by the Town of Fairview to ensure compliance with all city regulations applicable to the proposed work.

Contractor's Signature: _____ Date: _____

******* Email information to: permits@fairviewtexas.org
Information not received thru permits@fairviewtexas.org will not be processed.**



The Fairview Code of Ordinances, sections 14.02.204 (c) 8, 14.02.254 (c) 8 14.02.304 (c) 8, and 14.02.354 (c) 8 limit the maximum ground coverage of all buildings and impervious surfaces to 35% in the RE-1 district, 30% in the RE-1.5 district, and 25% in the RE-2 & RE-3 districts.

Violations may result in citation and removal of structures exceeding the total allowed impervious surface area. To comply with the ordinance, please complete the following form and have it notarized.

Address _____

House Pad	_____	sq ft.
Driveway	_____	sq ft.
Sidewalk	_____	sq ft.
Swimming Pool	_____	sq ft.
Swimming Pool Deck	_____	sq ft.
All current accessory buildings	_____	sq ft.
Other impervious surface	_____	
Proposed new use (s)	_____	sq ft.
	_____	sq ft.
	_____	sq ft.

Total square footage _____ (a)

Total Impervious Surface (sq ft) _____ (b)

Lot size (sq ft) _____

Impervious Surface to Lot Ratio

_____	divided by	_____	=	_____
Total Impervious Surface		Lot Area		Impervious Surface Ratio%

I hereby attest under penalty of law that the above information is true and correct:

_____	_____	_____
Signature of Surveyor, Architect, or Engineer	Print Name	Date

_____	_____	_____
Applicant Signature	Print Name	Date

State of Texas
County of _____

This instrument was acknowledged before me on _____
by _____.

Signature of Notary: _____
Printed Name: _____
My commission expires: _____



OUTDOOR LIGHTING CONFORMANCE CERTIFICATION

(This form covers all outdoor lighting excluding street lights and parking lot lights)

Town of Fairview Lighting Regulations

- Article 3.14 of the Town of Fairview Code of Ordinances
- Article 5 of the Commercial Plan Development District (CPDD) Standards and Guidelines (Adopted by Ordinance 2014-9-11B, as amended)

Please check if residential or commercial:

Residential Commercial

Fairview Address:

Please check the correct lighting district (Map located on page 3):

District 1 District 2

If in District 1, Article 3.14 of the Town of Fairview Code of Ordinances and Article 5 of the CPDD Standards and Guidelines requires the following (check the following if compliant):

- All exterior lighting fixture details have been submitted to the Town of Fairview for review and have been approved Article
- Lighting glare from any lighting source will not be directly visible from public view or from a residential unit and a maximum average of 1-foot candle at residential property lines has not been exceeded
- All fixtures are full cutoff. Any proposed fixtures not meeting the full cutoff requirement must be approved by minor warrant. All outdoor lighting fixtures approved by minor warrant shall not exceed 20,000 lumens per developed acre
- Lighting levels conform with standards established in Article 3.14 of the Town of Fairview Code of Ordinances and Article 5 of the CPDD Standards and Guidelines
- Lighting elements do not include flood, cobra head (unless LED), HID – mercury vapor and sodium vapor, high pressure sodium and fluorescent lights (except fluorescent bulbs that screw into standard socket fixtures)
- All other applicable provisions of Article 3.14 of the Town of Fairview Code of Ordinances and Article 5 of the CPDD Standards and Guidelines have been met on this site

If in District 2, Article 3.14 of the Town of Fairview Code of Ordinances requires the following (check the following if compliant):

- All exterior lighting fixture details have been submitted to the Town of Fairview for review and have been approved
- All outdoor lighting fixtures have been designed, located, installed, aimed downward or towards structures, retro fitted if necessary, and maintained in order to prevent glare, light trespass, and light pollution
- Light trespass at property lines does not exceed the maximum of 0.20-foot candles
- Light fixtures conform with shielding requirements applicable to fully shielded, partially shielded, and unshielded
- Lighting levels conform with standards established in Article 3.14 of the Town of Fairview Code of Ordinances
- All lamp types for new security lights are LED, metal halide, high-pressure sodium or low-pressure sodium. Security lights intended to illuminate a perimeter (such as a fence line) shall include motion sensors and be designed to be off unless triggered by an intruder located within five feet of the perimeter. The zone of activation sensors must be within the property boundaries of the property wishing to be illuminated.
- A maximum limit of 50,000 lumens per developed acre for all lighting irrespective of shielding conditions has not been exceeded. Unshielded and partially shielded lighting are limited to a maximum of 10,000 lumens per developed acre
- All floodlighting, that is not motion activated, is full cutoff or permanently directed downward
- Upward lighting is used in the form of one narrow cone spotlight for flags, statues, public art or other objects of interest that cannot be illuminated with down-lighting
- All other applicable provisions of Article 3.14 of the Town of Fairview Code of Ordinances have been met on this site

I, _____, do hereby certify that the exterior lighting
printed name

meets or exceeds the outdoor lighting standards of the Fairview Code of Ordinances.

Signature: _____ Date: _____

STATE OF TEXAS §

COUNTY OF _____ §

This instrument was acknowledged before me on the ____ day of _____,

20____, by _____

Notary Public State of Texas



Town of Fairview Lighting Districts

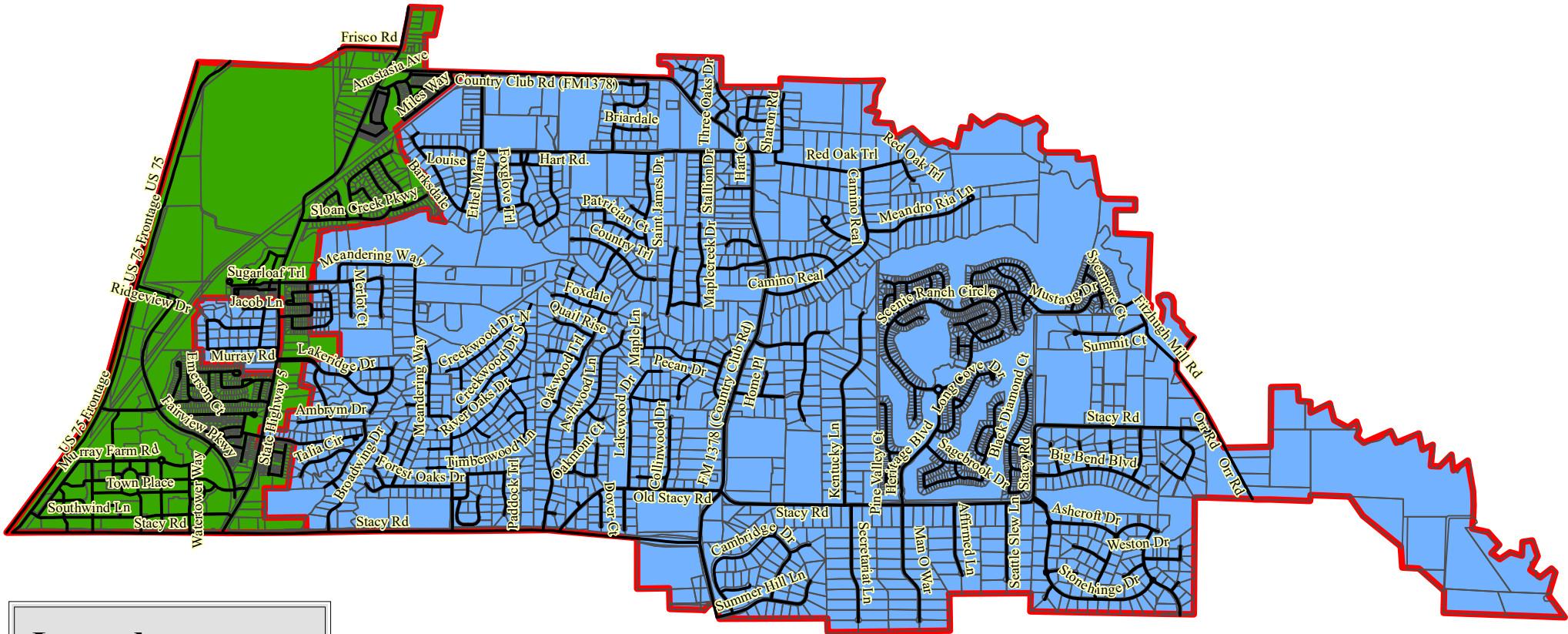

Legend

- Streets
- Fairview Parcels
- District 1
- District 2



Examples of Acceptable / Unacceptable Lighting Fixtures

Unacceptable / Discouraged

Fixtures that produce glare and light trespass

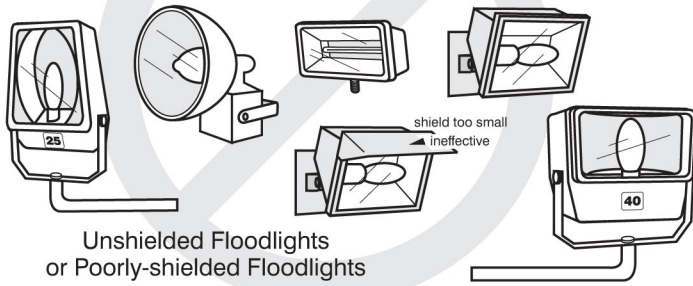

Unshielded Floodlights or Poorly-shielded Floodlights

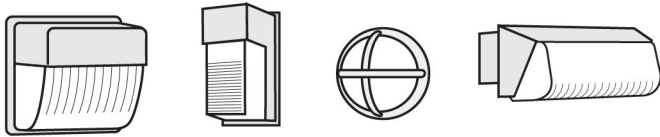

Unshielded Wallpacks & Unshielded or Poorly-shielded Wall Mount Fixtures

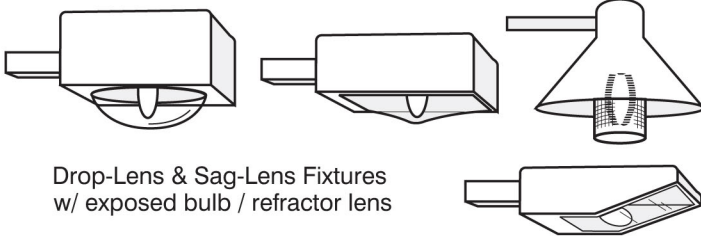
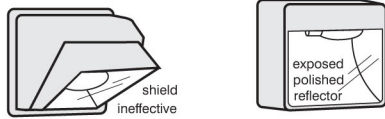

Drop-Lens & Sag-Lens Fixtures w/ exposed bulb / refractor lens

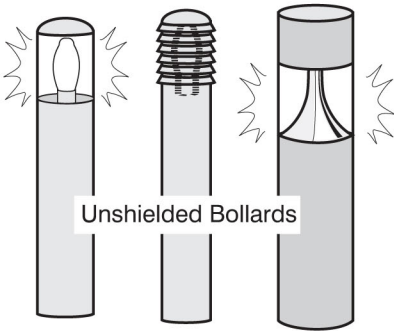

Unshielded Bollards

Unshielded Streetlight

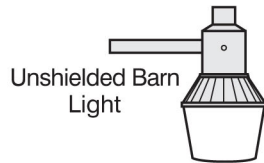

Unshielded Barn Light

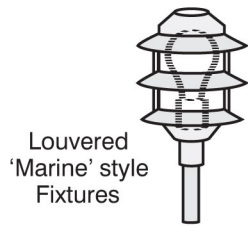

Louvered 'Marine' style Fixtures

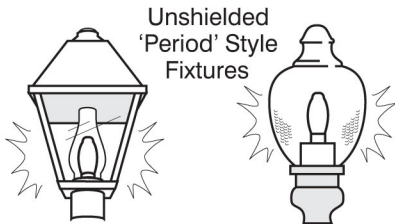

Unshielded 'Period' Style Fixtures



Unshielded PAR Floodlights

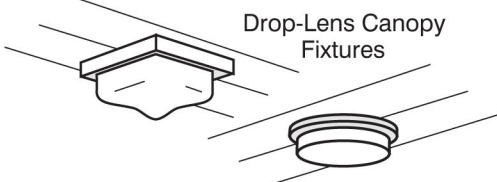

Drop-Lens Canopy Fixtures

Acceptable

Fixtures that shield the light source to minimize glare and light trespass and to facilitate better vision at night

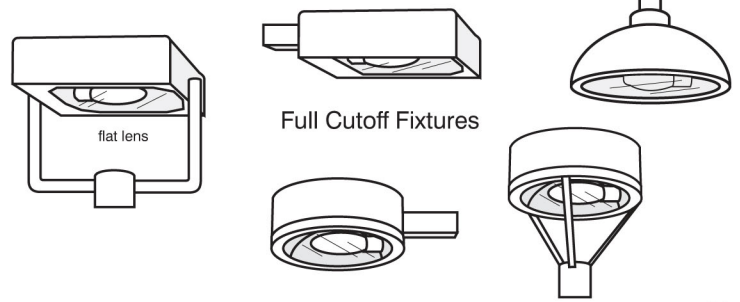

Full Cutoff Fixtures

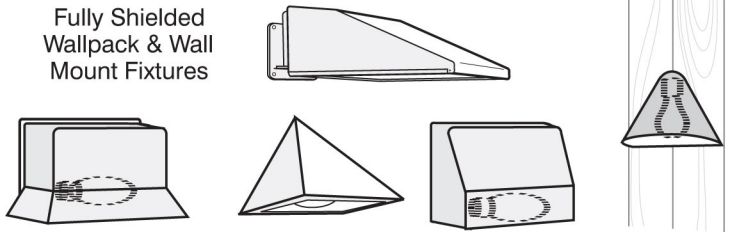

Fully Shielded Wallpack & Wall Mount Fixtures

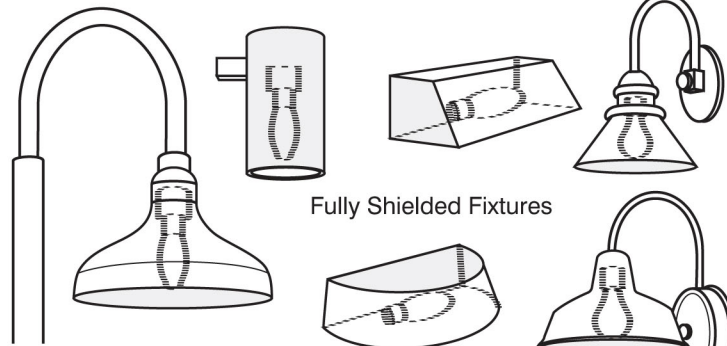

Fully Shielded Fixtures



Full Cutoff Streetlight

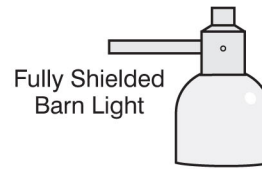

Fully Shielded Barn Light

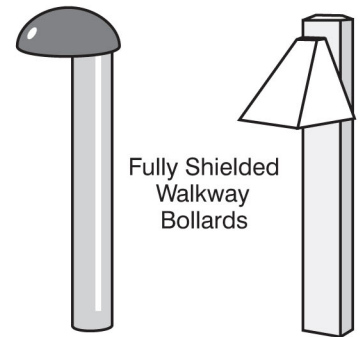

Fully Shielded Walkway Bollards



Fully Shielded Decorative Fixtures

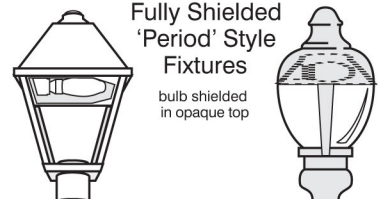

Fully Shielded 'Period' Style Fixtures

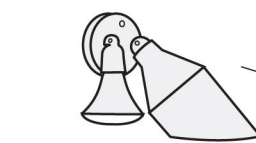

Shielded / Properly-aimed PAR Floodlights

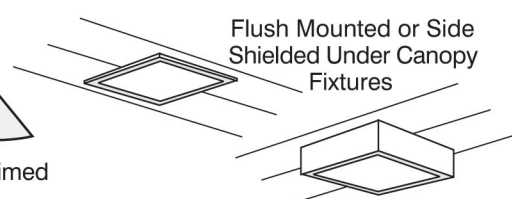

Flush Mounted or Side Shielded Under Canopy Fixtures



Dark Sky Ordinance

Fairview is dedicated to preserving the idyllic natural setting of this region. In 2006, we adopted a series of restrictions and guidelines designed to limit glare, reduce unnecessary light and control other light pollution. Our Dark Sky Ordinance helps to ensure adequate lighting only where it is needed in order to reduce spillover light between properties, increase safety for travelers and increase aesthetic value for our town. Our residents are able to take full advantage of a starry sky surrounded by plenty of nature, an experience unique to other cities in the DFW area.

Purpose and Intent: To regulate the installation and use of outdoor lighting fixtures in the town. This will improve night-time public safety, utility and security by restricting the night-time emission of light rays. These emissions are sources of light that trespass and cause unnecessary glare which are detrimental to the safety and security of persons, property and vehicular traffic.

Below is a compressed checklist for District 1 to act as an aid in compliance and not to replace or severe any of the requirements of Chapter 3 Building Regulations, Article 5 of the Commercial Plan Development District (CPDD) Standards and Guidelines, hereon referred to as the CPDD Security and Guidelines:

- Lighting glare from any lighting source will not be directly visible from public view or from a residential unit and a maximum average of 1-foot candle at residential property lines has not been exceeded
- All fixtures are full cutoff. Any proposed fixtures not meeting the full cutoff requirement must be approved by minor warrant. All outdoor lighting fixtures approved by minor warrant shall not exceed 20,000 lumens per developed acre
- Lighting levels conform with standards established in Article 3.14 of the Town of Fairview Code of Ordinances and Article 5 of the CPDD Standards and Guidelines
- Lighting elements do not include flood, cobra head (unless LED), HID - mercury vapor and sodium vapor, high pressure sodium and fluorescent lights (except fluorescent bulbs that screw into standard socket fixtures)

Below is a compressed checklist for District 2 to act as an aid in compliance and not to replace or severe any of the requirements of Chapter 3 Building Regulations, Article 3.14 of the Town of Fairview Code of Ordinances:

- All outdoor lighting fixtures have been designed, located, installed, aimed downward or towards structures, retro fitted if necessary, and maintained in order to prevent glare, light trespass, and light pollution
- Light trespass at property lines does not exceed the maximum of 0.20-foot candles
- Light fixtures conform with shielding requirements applicable to fully shielded, partially shielded, and unshielded
- Lighting levels conform with standards established in Article 3.14 of the Town of Fairview Code of Ordinances
- All lamp types for new security lights are LED, metal halide, high-pressure sodium or low-pressure sodium. Security lights intended to illuminate a perimeter (such as a fence line) shall include motion sensors and be designed to be off unless triggered by an intruder located within five feet of the perimeter. The zone of activation sensors must be within the property boundaries of the property wishing to be illuminated.
- A maximum limit of 50,000 lumens per developed acre for all lighting irrespective of shielding conditions has not been exceeded. Unshielded and partially shielded lighting are limited to a maximum of 10,000 lumens per developed acre
- All floodlighting, that is not motion activated, is full cutoff or permanently directed downward
- Upward lighting is used in the form of one narrow cone spotlight for flags, statues, public art or other objects of interest that cannot be illuminated with down-lighting
- Accent lighting may shine upward if the light is contained by the structure and the lamps are low intensity

OUTDOOR LIGHTING STANDARDS ARE DIFFERENT FOR DISTRICT 1 AND 2, BE SURE AND CHECK WHICH STANDARDS APPLY TO YOUR DEVELOPMENT.

Thank you for helping Fairview maintain its beauty at night as well as the daytime country living that we have all come to enjoy.

Examples of Acceptable / Unacceptable Lighting Fixtures

Unacceptable / Discouraged

Fixtures that produce glare and light trespass

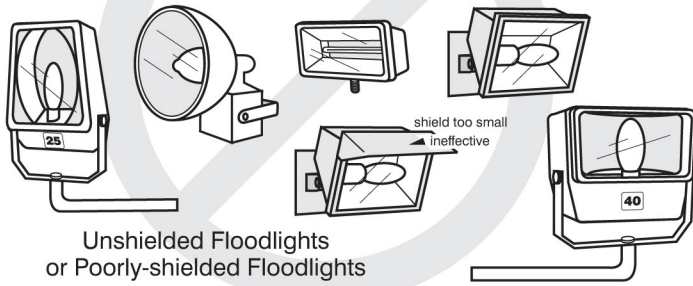

Unshielded Floodlights or Poorly-shielded Floodlights

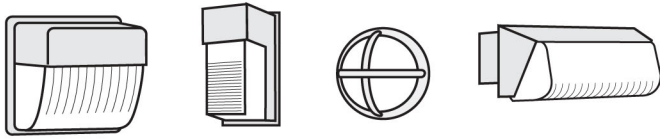

Unshielded Wallpacks & Unshielded or Poorly-shielded Wall Mount Fixtures

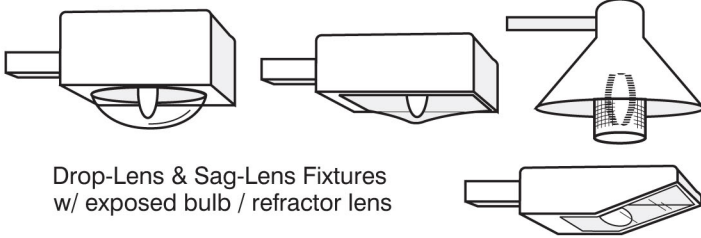
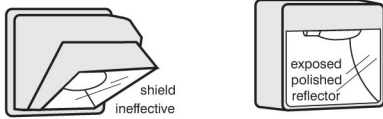

Drop-Lens & Sag-Lens Fixtures w/ exposed bulb / refractor lens

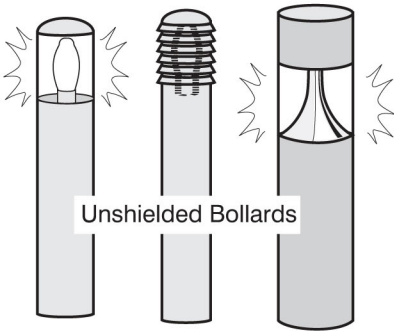

Unshielded Bollards

Unshielded Streetlight

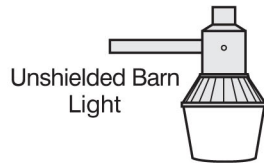

Unshielded Barn Light

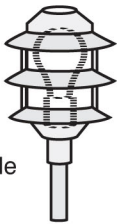

Louvered 'Marine' style Fixtures



Unshielded 'Period' Style Fixtures



Unshielded PAR Floodlights

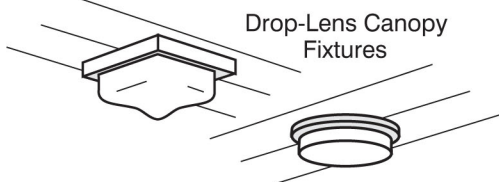

Drop-Lens Canopy Fixtures

Acceptable

Fixtures that shield the light source to minimize glare and light trespass and to facilitate better vision at night

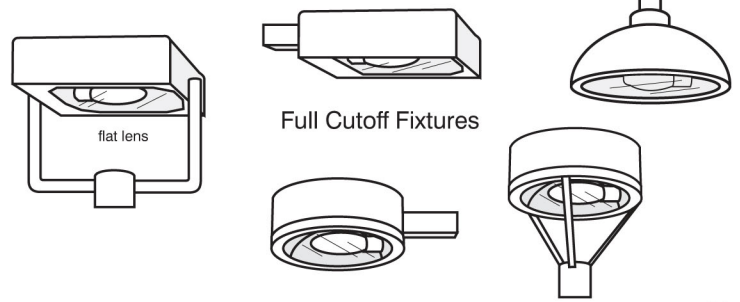

Full Cutoff Fixtures

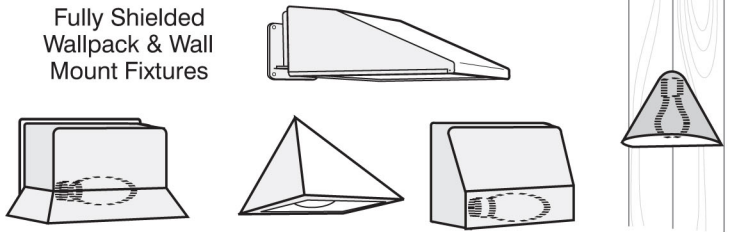

Fully Shielded Wallpack & Wall Mount Fixtures

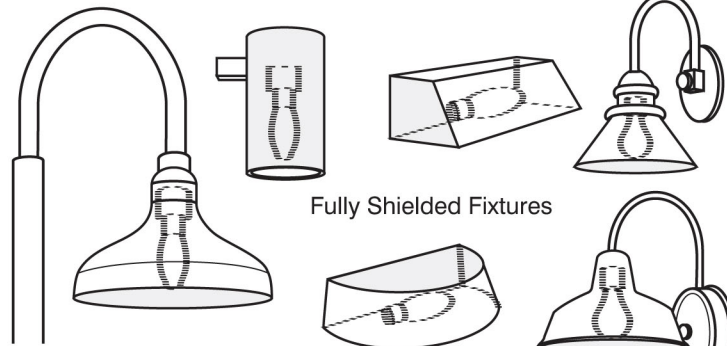

Fully Shielded Fixtures



Full Cutoff Streetlight

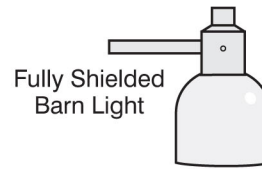

Fully Shielded Barn Light

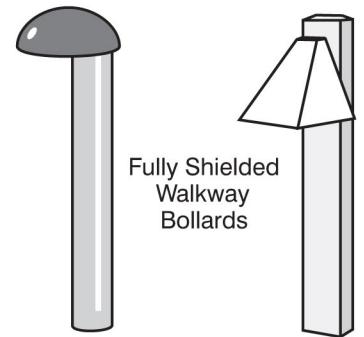

Fully Shielded Walkway Bollards



Fully Shielded Decorative Fixtures

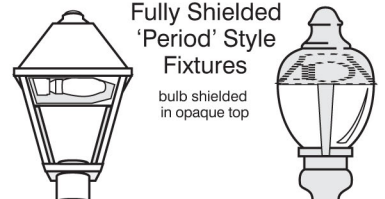

Fully Shielded 'Period' Style Fixtures

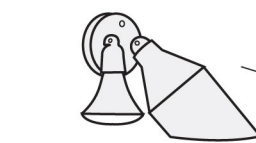

Shielded / Properly-aimed PAR Floodlights

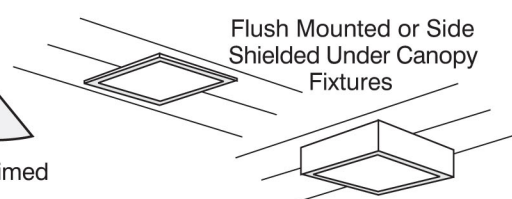

Flush Mounted or Side Shielded Under Canopy Fixtures



Protection Against Termites

Date: _____

Permit No: _____ Job Address: _____

Builder: _____

The residential address above meets or exceeds the requirements for protection against termites set forth in Section R318 of the 2018 International Residential Code.

Name of Protection Provider Company: _____

Address: _____

Phone: _____

State License No: _____



RELEASE FROM ELECTRIC AND GAS SERVICE

PERMIT NO: _____

ADDRESS: _____

BUILDER: _____

ELECTRIC PROVIDER: _____

GAS PROVIDER: _____

I hereby agree to release the Town of Fairview from any liability that may result from the granting of electrical and gas service to the above-referenced building project. I further agree that, if in the opinion of the electrical or gas inspector, unsafe electrical or gas conditions are found, that electrical or gas service will be terminated upon the request of the Town of Fairview to the provider of such service.

I further agree that I am responsible for the occupancy of the premises, and that if the building is occupied in any manner, including the storage of goods, the assignment of personnel to the premises, or the operation of a business or residence at the address listed above before Certificate of Occupancy is issued, the service, upon the request of the Town, will be discontinued without notice, and citations will be issued for each day the building is occupied without a Certificate of Occupancy.

State of Texas

County of Collin

I, _____, being duly sworn, do depose and say that the information contained in the above application is true and correct to the best of my knowledge and belief.

Signature of Owner or Owner's Agent

Date

Violations of move-ins without a C.O. will result in loss of any early meter sets. If you have any questions, please contact the inspector.

SOLID WASTE SERVICES CONTRACT

This Solid Waste, Construction and Demolition Debris, and Recyclable Materials Collection, Transportation, Disposal, and Processing Contract (“Contract”), is entered as of the effective date by and between the Town of Fairview, Texas, a Texas home rule municipality (hereinafter called "Town"), and Allied Waste Systems Inc., D/B/A Republic Services of Plano, hereinafter called “Contractor,” acting by and through their duly qualified representatives (Town and Contractor collectively referred to herein as “Parties” and individually as “Party”).

WHEREAS the Town, therefore, desires to grant to Contractor the right to operate as the sole provider for Town-provided services of collection, transportation, and disposal of residential, commercial, and industrial (both permanent and temporary) garbage and trash, construction and demolition debris, and recycling, subject to the terms of this Contract; and

WHEREAS Contractor desires to operate and maintain the services of collection, transportation, and disposal of residential, commercial, and industrial (both permanent and temporary) garbage and trash, construction and demolition debris, and recycling, subject to the terms of this contract,

NOW, THEREFORE, BE IT ORDAINED BY THE TOWN COUNCIL OF THE TOWN OF FAIRVIEW, TEXAS:

No commercial container, dumpster, or roll-off container should be overloaded to the point where the lid or covers, will not close, or the tarp will not properly cover the load. The Contractor may decline to empty an overloaded container until the Customer unloads the dumpster or roll-off container to the point where the lid(s) will close, or where the load may be safely tarped before transport.

To the extent allowed by law, this Contract will provide exclusive rights to Contractor for the collection of construction and demolition debris, and waste materials, such as carpeting, roofing, drywall, etc., resulting from remodeling and construction activities, which are generated in quantities requiring a roll-off container for onsite storage, collection, and transport.

Additional questions, service requests and concerns, should be directed to the Republic Services at 972.422.2341 or via their website at RepublicServices.com/Customer-Support.



Drainage and Grading Affidavit

I, _____, by filing this affidavit certify that I am the owner or authorized agent of _____; and further, certify that I have enclosed a record set of, or photocopy thereof, the Grading and Drainage Plans (*if disturbing more than one(1)acre*) to be included as part of the Building Permit Application for the following:

LOT: _____ **BLOCK:** _____ **SUBDIVISION:** _____

PROPERTY ADDRESS: _____

Furthermore, I certify that the lot grading of the aforementioned parcel will be consistent with the submitted plans. If it is determined by the Town of Fairview at a later date that the drainage configuration does not function as intended because the grading is not consistent with the attached plans, I will assume full responsibility to make corrections in order that the drainage will function as intended.

PRINT NAME: _____

SIGNATURE: _____ **DATE:** _____

ATTEST: THE STATE OF TEXAS: COLLIN COUNTY

BEFORE ME, the undersigned, a Notary Public in and for said County and State, on this day personally appeared known to me to be the person whose name is subscribed to the forgoing instrument and acknowledged to me that he or she executed the same for the purposed and consideration therein expressed.

GIVEN UNDER MY HAND AND SEAL OF OFFICE THIS

THE _____ DAY OF _____, _____

NOTARY PUBLIC

(SEAL)

372 Town Place
Fairview, TX 75069



Guidelines for Preparing Stormwater Pollution Prevention Plans for Construction Activities

Areas of Soil Disturbed	Submittal Requirements
Less than 1 acre and the site is not part of a larger common plan of development	Erosion Control Plan
Less than 1 acre and the site is part of a larger common plan of development outside urbanized area	
Less than 1 acre and the site is part of a larger common plan of development inside urbanized area	SWPPP
1 acre up to less than 5 acres	
5 acres and larger	SWPPP and copy of NOI filed with the State

Erosion Control Plans for a construction site are measures to prevent sedimentation and debris from going over sidewalks, into streets, gutters, inlets, drainage features, and neighboring properties during construction activities. Contractors and owners are responsible for keeping soil, sediment, and debris contained on the construction site and return soil and sediment to the areas to be stabilized, while properly disposing of debris. Plan of area must show entire site, limits of soil disturbance, location of construction entrance(s), and sediment barriers along the down slope perimeter of the disturbed areas. Stormwater Pollution Prevention Plans (SWPPP) include all elements of erosion control plans plus pollution control measures. When a SWPPP is required, the SWPPP Supplement to Permit Application form must accompany the construction and/or building plan submittals in addition to an adequate plan describing and ensuring implementation of practices that will be used to reduce the pollutants in stormwater discharges associated with construction activity at the construction site and assure compliance with the terms and conditions of a TCEQ or EPA stormwater permit. The contents and minimum requirements of a SWPPP can be found in the TPDES General Stormwater Requirements for Construction Activities dated March 5, 2008, or the most recent version as the regulations are updated. When applicable, the Notice of Intent (NOI) sent to the state shall be submitted to the Town electronically.

DISCLAIMER: The purpose of this guidance document is to assist the Owner and Operator of a construction activity within the Town of Fairview Ordinances. By providing this general guidance, the Town is not providing a guarantee of compliance or protection from enforcement under Town Ordinances. The Owner and Operator of a construction activity are fully responsible for being familiar with all the ordinance requirements and ensuring their construction activity is following the Town Ordinances and other state and federal regulations that are applicable to the construction activity.

Project Description: (Describe the type of construction activity and the type of development that will result from it.)	
Address of Construction Site:	
Legal Description of Construction Site: (Addition, Block, Lot)	
Acreage of Entire Site:	
Acreage Disturbed:	

Names of Contracting Company and Point of Contact:	
Contractor's Address:	
Contractor's Phone Number:	
Contractor's Email:	

Name of Property Owner:	
Owner's Address:	
Owner's Phone Number:	
Owner's Email:	

The **SWPP** must be in place prior to construction commencing and must comply with applicable notes at all times.



Inspection Request

Inspection hours are from 8:00am-4:00 pm Monday – Friday. To request your inspection please call the Inspection Request line at 972-886-4250 or at inspections@fairviewtexas.org before 4:00 PM to receive your inspection the next business day. If you call in your inspection on Saturday or Sunday you will not receive your inspection until Tuesday.

Please provide:

1. Your name
2. The address where work is to be inspected. Suite Numbers. Lock Box code and instructions to the inspector if needed for entry. Example: “Access hatch is in electrical room on north side of building “or “Homeowner will meet you between 11am and 1pm”
3. Call back telephone number/ onsite contact if required.
4. Permit number
5. Type of inspection
6. Time you are requesting the inspection to take place.
7. If you are requesting an RVI inspection, please have all photos uploaded to your permit prior to calling for RVI inspection.

Please note: When calling for inspections, the inspection will be scheduled for the next business day. If you need same day inspection, we must receive it by 8:00am or it will be assigned the next business day.

Emergency Inspections may be called in at anytime and will incur a \$75.00 inspection fee and must be paid prior to inspection. Emergency inspections on weekends will incur a \$150 inspection fee and you must call 469.628.4913. Please leave detailed voice mail and return contact number.



**Residential Energy Compliance Path Energy Code Requirements of
the 2024 IECC**

Submit with application for building permit.

Project Address: _____

2024 IECC Section R401.2 – Projects shall comply with one of the following (including local amendments):

___ Option 1 – Prescriptive: Sections R401 through R404 (N1101 - N1104)

The Prescriptive Compliance Option requires compliance with Sections R402 Through R404 and R408

Section R408 “Additional Efficiency Requirements” is deleted in its entirety. (amended by the Town of Fairview)

___ Option 2 - Simulated Building Performance Compliance: Section R405 (N1105)

The simulated Building Performance Option requires compliance with Section R405

___ Option 3 - Energy Rating Index Compliance: Section R406 (N1106)

Compliance with requirements from section R401 - R404 indicated in Table R406.2
HERS index is not valid for code compliance

The Energy Rating Index ERI Option requires compliance with Section R406

Maximum ERI values indicated in Table R406.5 (as amended by Town of Fairview)

CLIMATE ZONE	ENERGY RATING INDEX Not including OPP	ENERGY RATING INDEX With OPP
3	57	

² The table is effective from September 1, 2025, to August 31, 2028

**TABLE R406.5 (N1106.5) 3
MAXIMUM ENERGY
RATING INDEX**

CLIMATE ZONE	ENERGY RATING INDEX Not including OPP	ENERGY RATING INDEX WITH OPP
3	55	

³ This table is effective on or after September 1, 2028

___ Option 4 - Energy Star Certified Homes R104.1.1 (N1101.4)

Compliance with Sections R401 through R404 as indicated in the amended table R406.2
Compliance with Section R402.5.1.2 (N1102.5.1.2), R403.3.7 (N1103.3.7), R403.3.8 (N1103.3.8)
and R403.6.3 (N1103.6.3)

Each 1-and-2 family dwelling shall be tested.

Amended Section R104.1 by the Town of Fairview

R104.1.2 (N1101.4.1) Alternative compliance. *A building certified by a national, state, or local accredited energy efficiency program and determined by the Energy Systems Laboratory to be in compliance with the energy efficiency requirements of this section may, at the option of the code official, be considered in compliance. The United States Environmental Protection Agency's Energy Star Program certification of energy code equivalency shall be considered in compliance. Regardless of the program or the path to compliance, each one- and two-family dwelling shall be tested for air and duct leakage as prescribed in Section R402.4.1.2 (N1102.4.1.2) and R403.3.3 (N1103.3.3), respectively.*

___ Option 5 - HB 3215 (87R) Home Energy Rating System Index Compliance

Includes compliance with ANSI/RESNET/ICC 301, as it existed on January 1, 2021.
Includes compliance with the Mandatory requirements of 2018 IECC Section R406.2.
Includes compliance with Building thermal envelope provision of 2018 IECC R402.1.2 or 2018 IECC
Or 2018 IECC R402.1.4

ATTACH APPROPRIATE SITE-SPECIFIC DESIGN COMPLIANCE REPORT AND INSPECTION CHECKLIST.

NAME AND VERSION OF THE COMPLIANCE SOFTWARE (IF SELECTING Option 2-5): _____

I certify that I have reviewed the construction documents including, but not necessarily limited to, insulation materials and R-values; fenestration U-factors and SHGC values; area-weighted average U-factor and SHGC calculations; mechanical system design criteria; mechanical and service water heating system and equipment types, sizes and efficiencies; equipment and system controls; duct sealing, duct and piping insulation and location; and air sealing details; and that the project as designed satisfies the minimum requirements for the compliance approach selected above and the Texas State mandated IECC requirements for ERI compliance path.

Agency and Certification Number: _____

Signature of Responsible Party: _____

Printed Name and Title of Responsible Party: _____



Residential Energy Compliance Certificate Energy Code Requirements of the 2024 IRC (IECC) as amended

MECHANICAL VENTILATION AIRFLOW TESTING VERIFICATION R403.6.3 (N1103.6.3)

Whole-house System #1 - _____ CFM Whole-house System #2 - _____ CFM

Mechanical Ventilation Fan Efficacy meets the requirements of R403.6.2 and Table R403.6.2 I certify that I have conducted whole-house mechanical ventilation airflow testing and the Mechanical Ventilation Systems(s) have passed the requirements of the 2024 International Energy Conservation Code, 2024 International Residential Code or International Mechanical Code as applicable and as amended locally. I further certify the testing was conducted in accordance with ANSI/RESNET/ICC 380. I certify I am an independent third-party entity and have not installed the HVAC system; nor am I employed or have any financial interest in the company that constructs the structure.

Agency and Certification Number: _____

Signature of Responsible Party: _____

Printed Name and Title of Responsible Party: _____

* Per R402.5.1.3 (1102.5.1.3): The maximum infiltration rate for Option 1 Prescriptive Path is 3.0 ACH in Climate Zone 3. The maximum infiltration rate for all other compliance paths and climate zones is 4.0 ACH or 0.22 CFM per SF of the building thermal envelope area or the dwelling unit enclosure area, as applicable.

Compliance Statement

We have concluded all inspections, testing and plan reviews of the above project and hereby declare it in compliance with the residential provisions of the 2024 IECC as amended locally for the selected compliance approach.

- _____ **Option 1 – Prescriptive: Sections R401 – R404**
- _____ **Option 2 – Simulated Building Performance Compliance: Section R405**
- _____ **Option 3 – Energy Rating Index Compliance: Section R406 HERS index is not valid**
- _____ **Option 4 – Energy Star Certified Homes R104.1.1**
- _____ **Option 5 – HB 3215 (87R) Home Energy Rating System Index Compliance**

Agency and Certification Number: _____

Agency Contact Information: _____

Signature of Responsible Party: _____

Printed Name and Title of Responsible Party: _____

372 Town Place, Fairview, Texas 75069 | 972-886-4209 | Permits@FairviewTexas.org